

國立臺灣科技大學
九十三學年度碩士班考試試題

系所組別：高分子工程系丙組
科 目：控制系統

總分 100 分

1. A unity feedback system with a forward transfer function,

$$G(s) = \frac{K}{s(s+7)}$$

is operating with a closed-loop step response that has 15% overshoot. Do the following:

- Evaluate the steady-state error for a unit ramp input to uncompensated system. (8%)
- Design a cascade lag compensator to improve the steady-state error by a factor of 20 by adding an open-loop pole at (-0.01). (8%)
- Evaluate how much improvement in steady-state error was realized. (8%)
- Use the following active network to realize the lag compensator. (6%)

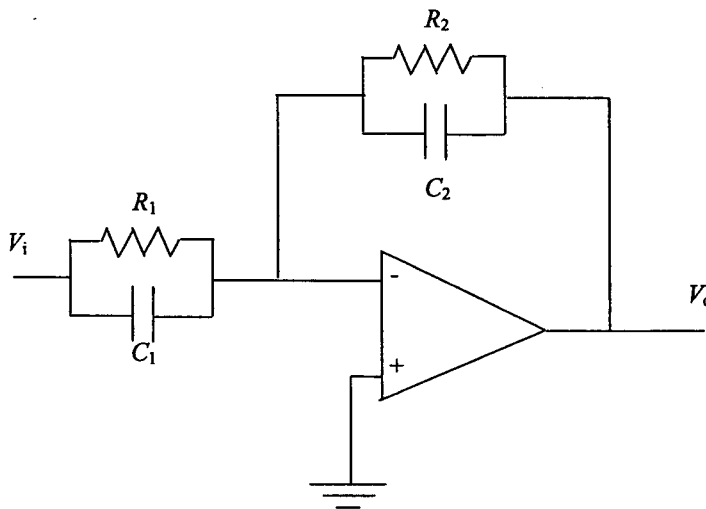

2. A specific closed-loop control system is to be designed for an underdamped response to a step input. The specifications for the system are as follows: (15%)

Percent overshoot $\leq 5\%$

Settling time ≤ 4 seconds (Use a 2% settling time)

Peak time ≤ 1 second

- Sketch the desired area for the dominant poles of the system in the s-plane.
- The transfer function $T(s)$ of the closed-loop system is third-order. Determine the transfer function $T(s)$ when the percent overshoot is 5% and the peak time is 1 second.

3. Given the unity feedback system shown in the figure, where (15%)

$$G(s) = \frac{K}{s(s+2)(s+6)} \quad K > 0$$

- Sketch the root locus.
- Determine the value of K such that the dominant closed-loop poles have the damping ratio of 0.6. Also find the locations of all the closed-loop poles at this value of K .

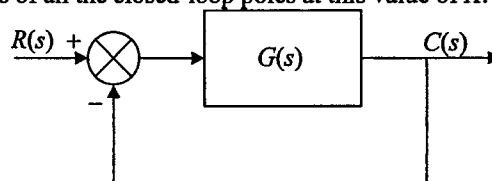

國立臺灣科技大學
九十三學年度碩士班考試試題

系所組別：高分子工程系丙組
科 目：控制系統

4. A simple pendulum is shown below. Determine the equations of motion,
 (1) if the mass of the rod M is small compared to the mass m at the end, (10%)
 (2) if the mass of the rod is not negligible. (10%)

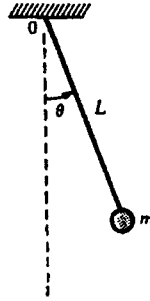

5. A double physical pendulum of mass m_1 and m_2 is shown. O_1 and O_2 are the mass centers and J_1 and J_2 are the moments of inertia of the pendulums with respect to the axis of rotation. a_1 and a_2 are the distances from the mass centers to the corresponding pivoted points respectively. Determine the equations of motion. (20%)

